



The 16C-to-5C Spindle Adapter is designed specifically for use with Hardinge A2-5 16C spindle machines with 1⁵/₈" through-collet capacity. The adapter allows the use of standard and special shape 5C collets, 5C stop collets, 5C collet fixture plates and 5C master expanding collets – all sold separately.

Warning: DO NOT USE CAST IRON 5C WORKHOLDING FIXTURES.

Caution: If coolant will not be used, the bearing and taper surfaces of the 5C collet should be coated with molybdenum disulfide grease.

Mounting Instructions

1. Loosen Set Screw "C" enough to permit separation of the Draw Tube and the Reducer Bushing.

Note: Key Screw "B" acts as a key for the 5C collet. It may be necessary to loosen screw "B" slightly to allow the tooling to slide in smoothly.

2. Place the desired 5C Collet in the Reducer Bushing.
3. Thread the Draw Tube onto the Collet and draw the tool into the Reducer Bushing until the tool is locked firmly in place.

Note: There are four slots milled on the O.D. of the Draw Tube. Four corresponding lines are etched on the O.D. of the draw tube to indicate the location of each of the milled slots.

4. Turn Draw Tube counterclockwise until one of the etched lines is aligned with Set Screw "C".
5. Tighten Set Screw "C" until it bottoms against the Draw Tube and then back the screw off one quarter-turn.

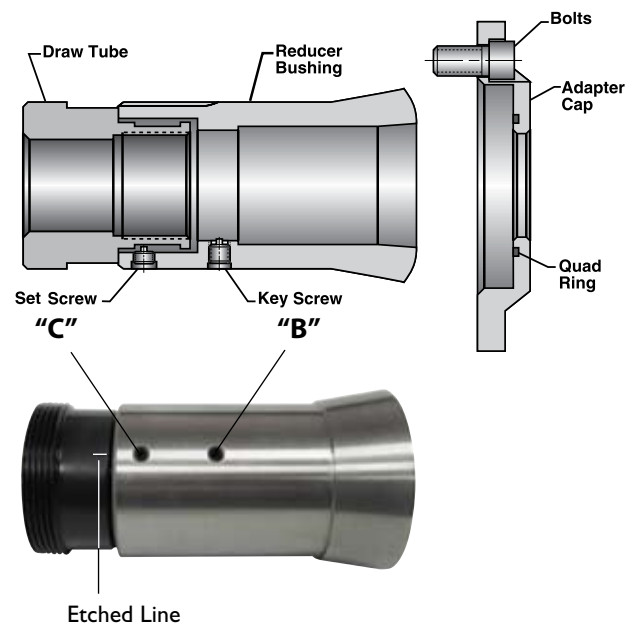

16C-to-5C Spindle Collet Adapter Instruction Sheet B-050-E

Note: It is NOT necessary for the keyways in the Reducer Bushing and Draw Tube to be aligned.

6. Align the Draw Tube keyway with the spindle key and slide the assembly into the spindle. If necessary, rotate the Reducer Bushing to align its keyway with the spindle key and slide the assembly into the spindle.
7. Install the assembly in the machine spindle following the directions outlined in the machine's Programmer's and Operator's manual. Draw the adapter into the spindle unit until it is fully seated.
8. Adjust the collet closer gripping pressure as outlined in the Programmer's and Operator's manual.



Note: A properly assembled unit will allow the 5C collet to move back and forth approximately 1/8 inch (3.175mm).

9. Install the Adapter Cap on the spindle with the three screws provided.

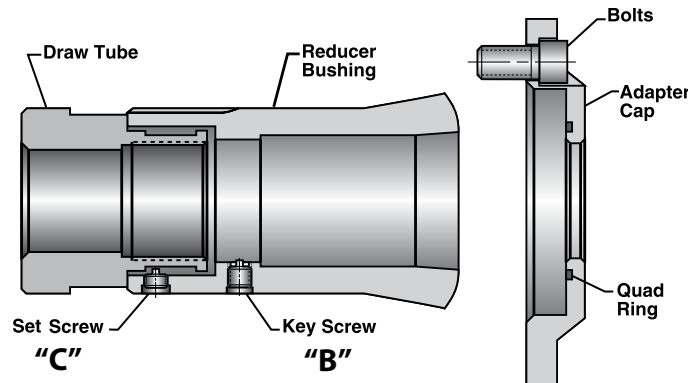

Spindle Collet Adapter – Parts List

Description	A2-5 Spindle 16C to 5C Part Number
Adapter Assembly - including:	16B-0000185-5C
— Draw Tube Adapter	16A-0000301-5C
— Reducer Bushing	16A-0000186-5C
— Bolts [3]	CC-0007373
— Adapter Cap	16B-0010768
— Quad Ring	40-0011151-32
— Key Screw	16-0000338-5C
— Set Screw	N-0590304-L
— Permabond 910*	QC-0010884

* Use Permabond adhesive to secure a new quad ring to the adapter cap when necessary.